

# MixMaster

## MIXER-GRINDER



## MG 50 MIXER/GRINDER

**All Stainless Steel Construction (bowl, ring, auger)**

**Independent Direct Drive on mixing and grinding operations ♦ Forward and Reverse Mixing**

**Stainless Steel Lid with Safety Switch ♦ # 32 Stainless Steel Bowl ♦ Easy to clean**

**Low Maintenance ♦ Table-Top**

**Options: Machine Cart, Single Tub Dolly, Hopper Funnel, Foot Switch**

We provide  
technical support and  
service for all machines  
that we sell

# MPBS INDUSTRIES

Equipment for Industrial Food Processing & Packaging

2820 East Washington Blvd. Los Angeles CA 90023  
323-268-8514 ♦ 323-268-6305 (fax) ♦ www.mpbs.com  
Hours: 8:00 - 4:30 PM  
Se Habla Espanol



Since 1938

# MixMaster

## MG 50 Mixer Grinder

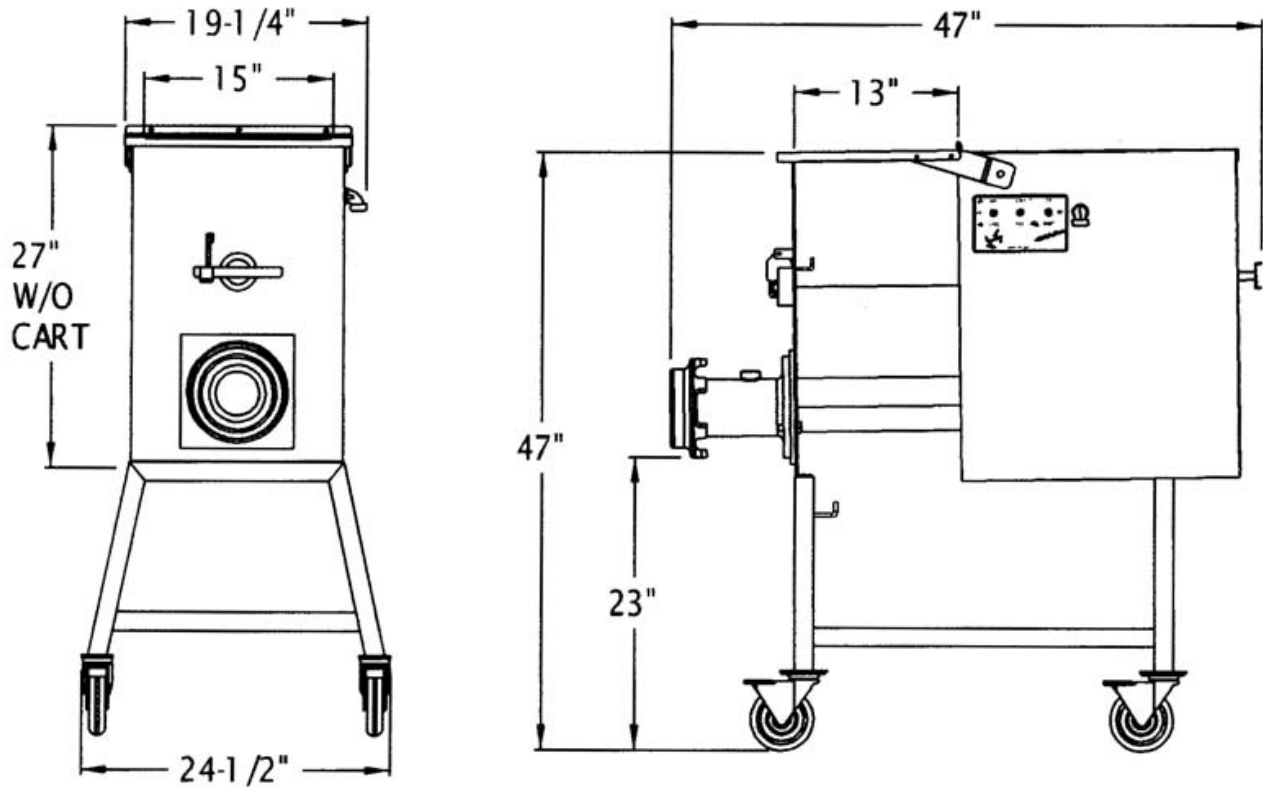

<b>MixMaster MG-50 Mixer Grinder</b> <b>Technical Specifications</b>	
<b>Standard</b>	<b>Grinder:</b> 230 V / 60 Hz / 3 Ø; 8.2 amps; 3 HP <b>Mixer:</b> 230 V / 60 Hz / 3 Ø; 1.9 amps; ½ HP <b>Total:</b> amp draw 10.1 amp
<b>Construction</b>	<ul style="list-style-type: none"> <li>• Heavy gauge stainless steel construction</li> <li>• 75 lb Capacity</li> <li>• Removable paddle</li> <li>• Stainless steel hopper cover with safety lockout</li> </ul>
<b>Output</b>	Up to 100 lb per minute with 3/8" plate
<b>Options</b>	<ul style="list-style-type: none"> <li>• 208 V / 60 Hz / 3 Ø; Total amp draw 10.9 amp</li> <li>• 208 V / 60 Hz / 1 Ø; Total amp draw 29.8 amp</li> <li>• 208 V / 60 Hz / 1 Ø; Total amp draw 26 amp</li> <li>• 208 V / 60 Hz / 3 Ø; Total amp draw 5.05 amp</li> </ul>
<b>Weight</b>	355 lb
*All specifications are subject to change without notice	

MixMaster by: MPBS Industries

Distributed by: