



PRO-SAW® MEAT BANDSAWS

THE ULTIMATE IN SAFETY AND SANITATION!



**SS-16E
SS-16HD**



SS-20HD



SS-16HS

**Quality
Dependability
Service**

**We provide
technical support and
service for all machines
that we sell**

MPBS INDUSTRIES

Equipment for Commercial Food Processing & Packaging

323-268-8514 800-421-6265 www.mpbs.com



Since 1938

◀◀ FEATURES & SPECIFICATIONS ▶▶▶

General Features:

- All stainless steel construction
- Heavy-duty
- Motor
 - 2 HP TEFC motor (SS-16E)
 - 3 HP TEFC motor (SS-16HD, SS-16HS)
 - 5 HP TEFC motor (SS-20HD)
- Electrical: 208-220/440 V / 60 Hz / 3 Ø
- Speed
 - Standard speed: 4000 FPM
 - High speed: 6000 FPM (SS-16HS)
- Table lock feature
- Adjustable legs for precise leveling
- Sliding table (4 Delrin rollers)
- Revolutionary thickness gauge with steak guide for accurate cuts
- USDA standards (SS-16E, SS-16HD, SS-16HS)
- Bandsaw Blade
 - SS-16: 5/8" x 126" x .014 to .025 thickness
 - SS-20: 5/8" x 154" x .014 to .025 thickness
- Weight
 - SS-16: 390 lb
 - SS-20: 550 lb

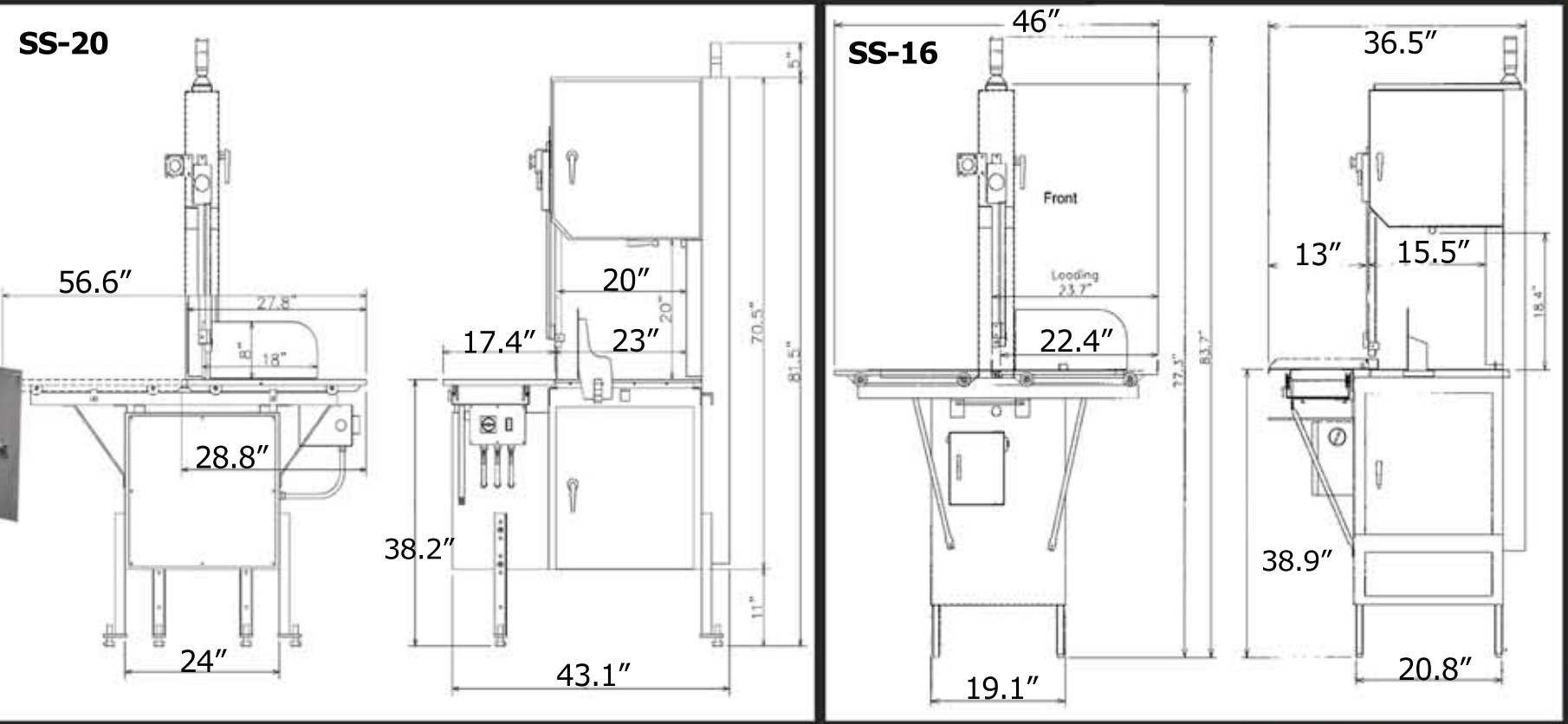
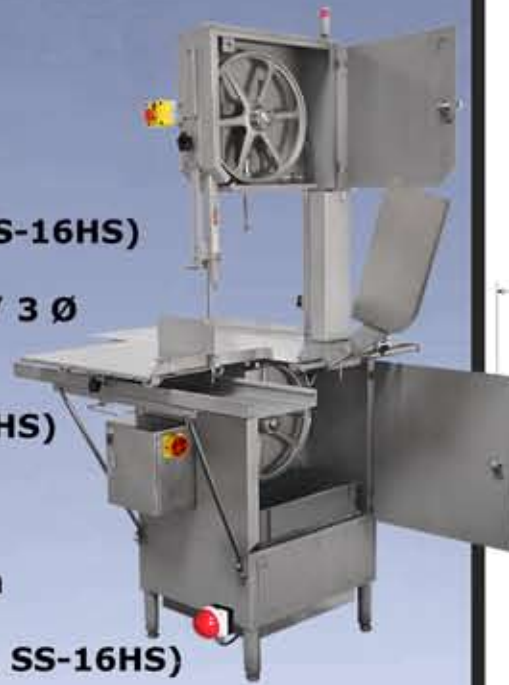

Sanitation:

- Wheels
 - Tinned cast iron wheels (SS-16E)
 - 100% Stainless wheels (SS-16HD, SS-16HS, SS-20HD)
- Sealed wheel bearings
- Removable front and rear table for easy cleaning
- Removable wheel and blade cleaner system
- Disassemble main components easily without tools
- Deep tray
- 100% Washdown

Safety:

- 2 Hand safety start feature
- Thumb protector
- Magnetic safety switches in both wheel covers
- Lower tension handle
- Indicator light
- Emergency stop button
- Emergency stop foot switch
- Totally enclosed, waterproof electric brake motor (SS-16HS, SS-20HD)
- Motor controls:
 - Starter with overload protection
 - Stop/start control box (NEMA IV)

Option:

- Single phase available (SS-16E, SS-16HD)



Commercial Food
Preparing Machines
E241294
13HS



Conforms to
NSF/ANSI 8

3108945

All specifications are subject to change without notice.

SS-16E, SS-16HD, SS-16HS, SS-20HD Meat Bandsaws



NEMA IV Control Box



Indicator Light



Emergency Stop Button



Brake Motor



Deep tray



Lower Tension Handle



Emergency Foot Switch



Magnetic Safety Switches