

Industrial Cutters

IC - 3000

Pro-Slice High-Speed Portion Slicer



We provide
technical support and
service for all machines
that we sell

MPBS INDUSTRIES

Equipment for Industrial Food Processing & Packaging

2820 East Washington Blvd. Los Angeles CA 90023
323-268-8514 ♦ 323-268-6305 (fax) ♦ www.mpbs.com
Hours: 8:00 - 4:30 PM
Se Habla Espanol



Since 1938

Pro-Slice 3000 High-Speed Portion Slicer



Product Grader



Check Weigher



Features:

- State of the art technology for high precision yet minimal waste cutting
 - High-speed
 - Fixed weight
 - Fixed thickness
- Stainless steel construction (AISI 304 and FDA approved food plastics)
- Conveyor belt: Polyurethane interlock
- Keyboard: IP67 with integrated electronics
- User friendly Z1 indicator with UTP/IP connection
- Internet direct connection for remote flexible servicing
- Machine special features:
 - Product is fed on the in-feed belt
 - Three dimensional laser scanner calculate size of product
 - Preset weight and shape frame is selected from the program menu
- Products
 - Fish (fillet, whole)
 - Meat
 - Poultry
- Options:
 - Multiple camera system for highest accuracy with round objects
 - MCI check weigher for precision optimization
 - Grader for fixed weight packages



Pro-Slice 3000 High-Speed Portion Slicer

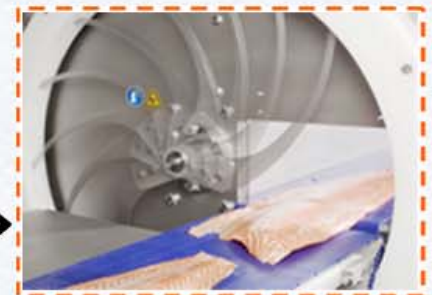

Multiple Blades for High-Speed Slicing

Cleaning:

- Machine can be open easily for easy cleaning
- Belts can be taken out for separate cleaning

Pro-Slice 3000 High-Speed Portion Slicer

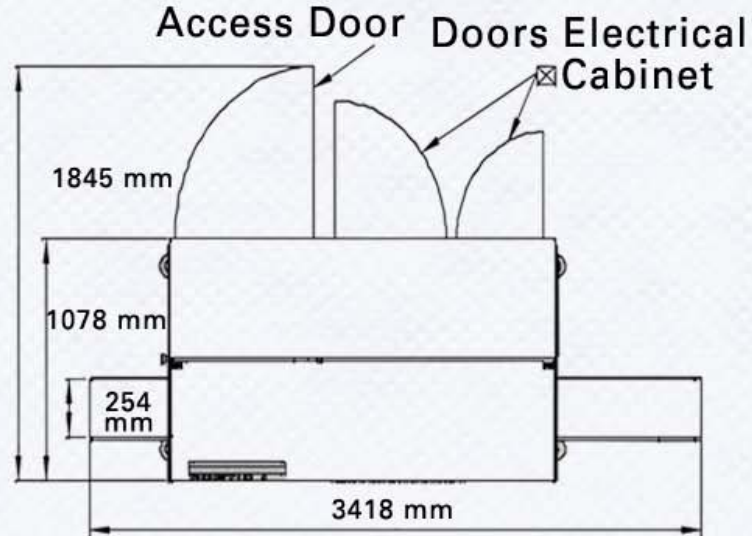
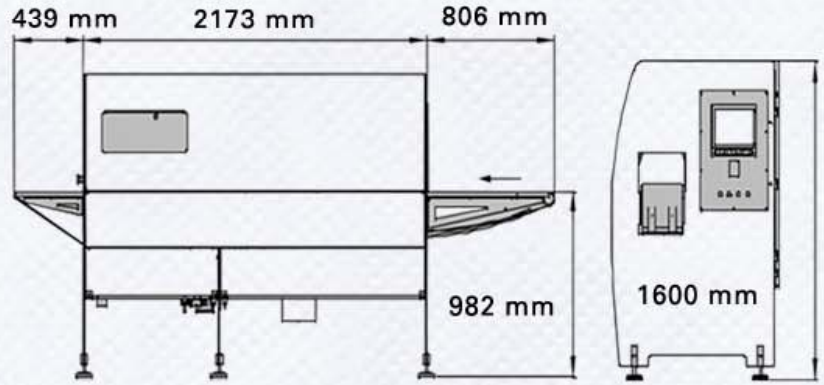

Technical Specifications

- Maximum product dimensions: 31.50" x 9.5" (800 x 240 mm)
- Air supply: 6 bar, 200 norm liter/min.
- Belt width: 10.25" (260 mm)
- Belt speed: 15.7"/second (40 cm/s)
- Rate: Up to 10 cuts/second
- Precision: 1.5 g (0.047 oz.) standard deviation on portions less than 150 g and 1.5% of portion weight on portions higher in weight
- Completely water tight
- ETL, ETL8 sanitation
- Voltage: 230 V / 60 Hz (5 kW)
- Weight: 2072 lb (940 kg)

* All specifications are subject to change without notice.

Pro-Slice® by MPBS Industries

Distributed by: