

PRO-SLICE®

The Perfect Fit for the Meat Processing Industry

PRO-SLICE TT-400 TENDERIZER OPERATION AND MAINTENANCE

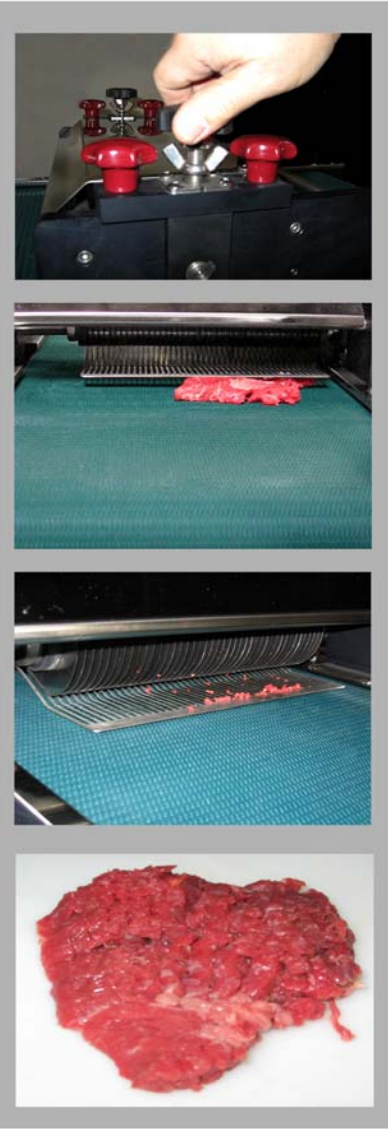

We provide
technical support and
service for all machines
that we sell.

MPBS INDUSTRIES

Equipment for Industrial Food Processing & Packaging

2820 East Washington Blvd. Los Angeles CA 90023
323-268-8514 ♦ 323-268-6305 (fax) ♦ www.mpbs.com
Hours: 8:00 - 4:30 PM
Se Habla Espanol



Since 1938

PRO-SLICE®

TT-400 TENDERIZER



Tenderizing cradle



Neoprene Conveyor



Features:

- Stainless steel safety cover and plastic turn knob
- One set of stainless steel tenderizing blades
- Easy cleaning and maintenance
- Energy efficient
- Easy adjustable wing nut to control tenderizing depth

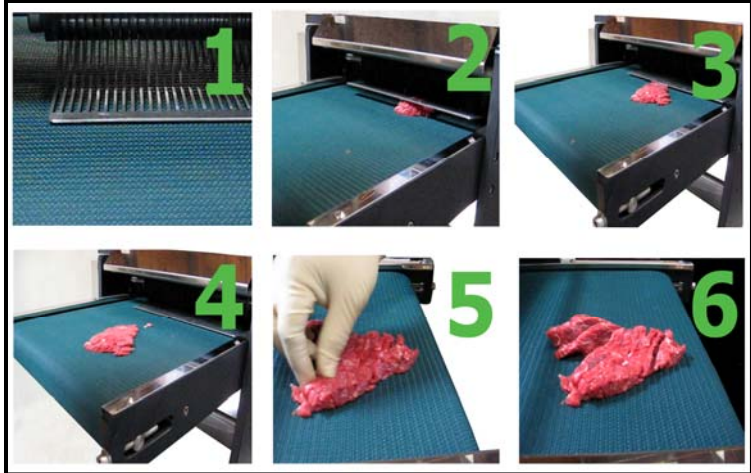

Product comes out on the discharge conveyor and slides down to the meat lug.

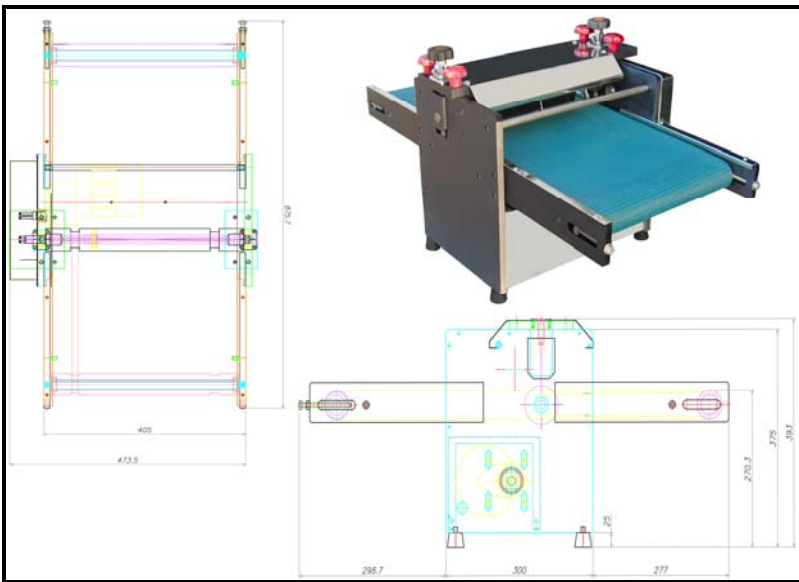

Pro-Slice TT-400 Tenderizer Technical Specifications	
Maximum belt speed +/-	32' per minute
Electrical	220 V / 60 Hz / 1 Ø 1/2 HP, 400 Watts
Capacity	1,900 - 2,400 lb/hr
Neoprene infeed conveyor (L x W) +/-	876 x 405 mm (19.50" x 31")
Overall dimensions (L x W x H) +/-	876 x 495 x 444.5 mm (19.50" x 34.50" x 17.50")
Knife size +/-	101.60 mm (4" diameter)
1 set of tenderizing blades	6 mm (1/4")
Weight +/-	60 lb (27 kg)

WARNING:



Always wear safety gloves when handling tenderizing blades/cradle.

Do not operate Pro-Slice TT-400 Tenderizer without the s/s safety cover.

Make sure the *power is off* before cleaning or maintenance.

* All specifications are subject to change without notice

Pro-Slice Tenderizer by MPBS Industries

Distributed by: