

# Vacu-Fresh®

Ready

Fresh

GO!

## VFCV SERIES CONTINUOUS VACUUM PACKAGING MACHINES

*Advanced European Technology at Affordable Prices*



Extends Shelf Life

Enhances Color & Taste

Reduces Shrink

Reduces Oxidation



### VFCV-1000, VFCV-1200 CONTINUOUS VACUUM PACKAGING MACHINE

#### DESIGNED TO OUTPERFORM TRADITIONAL CHAMBER VACUUM PACKAGING MACHINES!

- Stainless steel construction • 12-Program microprocessor with oil indicator
- (IP56) Water resistant touch pad control panel • Durable aluminum sealing bar with 10 mm wide seal
- Conveyor belt: Semi-automatic or continuous operation, stainless steel chain, easy wash-down
- Busch® vacuum pump • Heavy-duty caster wheels • Package liquid products
- Maximum durability • Upgrades production output and saves manpower

- ▶ Higher Productivity
- ▶ Better Seal
- ▶ Easier Cleaning & Maintenance
- ▶ Reduced Noise
- ▶ More Package Sizes

We provide technical support and service for all machines that we sell.

## MPBS INDUSTRIES

Equipment for Industrial Food Processing & Packaging

2820 East Washington Blvd. Los Angeles CA 90023  
323-268-8514 ♦ 323-268-6305 (fax) ♦ www.mpbs.com  
Hours: 8:00 - 4:30 PM  
Se Habla Espanol



Since 1938

## VFCV Series Vacuum Packaging Machines

### Technical Specifications

MODELS	VFCV-1000	VFCV-1200
Seal Bar Length	41" (1050 mm)	41" (1050 mm)
Distance Between Seal Bars	18" (460 mm)	22" (550 mm)
Chamber Depth	7" (180 mm)	8" (200 mm)
Vacuum Pump Capacity	100 m <sup>3</sup> /h (5 HP / 3 kW)	302 m <sup>3</sup> /h (12 HP / 10 kW)
Voltage	220 V / 60 Hz / 3 Ø (20 amps)	220 V / 60 Hz / 3 Ø (48 amps)
Cycle	3 ~ 5 min	3 ~ 5 min
Machine Weight	990 lb (450 kg)	1295 lb (588 kg)

\*All specifications are subject to change without notice

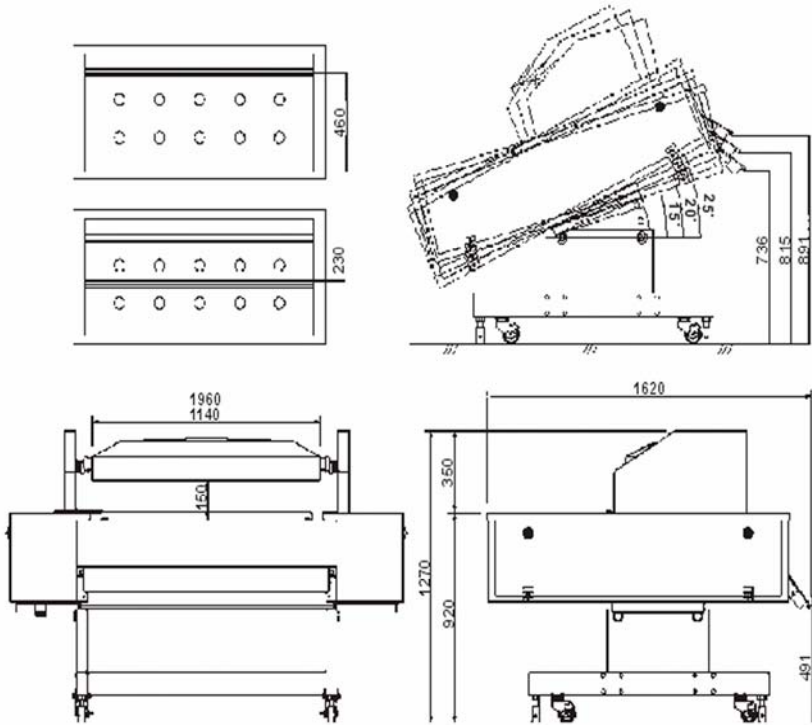

### OPTIONS:

- ◆ Conveyor table
  - ◆ In-feed and/or exit
- ◆ Custom size available
- ◆ Dual seal bars
- ◆ Gas flush
- ◆ Perforator knife system
- ◆ Sensor control
- ◆ Vacuum pump
  - ◆ 205 m<sup>3</sup>/h
  - ◆ 305 m<sup>3</sup>/h
- ◆ Voltage