

Vacu-Fresh®

Ready

Fresh

GO

Hot Water Shrink Tanks or Shrink Tunnels
Advanced European Technology at Affordable Prices



VFST-10



VFST-700 & VFST-1000



VFST -10, VFST-700, VFST-1000 HOT WATER SHRINK DIP TANKS

DESIGNED TO OUTPERFORM TRADITIONAL PACKAGING MACHINES!

Stainless Steel Construction • Electric Heating • Programmable Temperature Control

Simple Push Button Cycle Operation (VFST-10) • ON/OFF Indicator Light • Easy Access for Cleaning and Maintenance • High Performance Insulation to Avoid Heat Loss • Easy Fill and Drain Tank • Low Energy Consumption • Auto Dip Tank with Conveyor (VFST-700 & VFST-1000)

► Higher Productivity ► Easier Cleaning & Maintenance ► Reduced Noise

We provide
technical support and
service for all machines
that we sell.

MPBS INDUSTRIES
Equipment for Industrial Food Processing & Packaging

2820 East Washington Blvd. Los Angeles CA 90023
323-268-8514 ♦ 323-268-6305 (fax) ♦ www.mpbs.com
Hours: 8:00 - 4:30 PM
Se Habla Espanol



Since 1938

Hot Water Shrink Dip Tanks

Technical Specifications

MODEL	VFST-10	VFST-700	VFST-1000
Maximum Product Height	12" (305 mm)	11" (275 mm)	11" (275 mm)
Immersion Platform Size (A)	23" (580 mm)	34" (870 mm)	43" (1092 mm)
Immersion Platform Size (B)	14" (350 mm)	25" (630 mm)	35" (886 mm)
Immersion Depth (D)	14" (355 mm)	13" (330 mm)	13" (330 mm)
Cycle Time	Up to 15 / min	Up to 8 / min	Up to 8 / min
Volume of Water	30 gal / 100 liters	85 gal / 320 liters	103 gal / 390 liters
Power	32 amps, 10 kW	80 amps, 25 kW	141.20 amps, 45 kW
Voltage	230 V / 60 Hz / 3 Ø	230 V / 60 Hz / 3 Ø	230 V / 60 Hz / 3 Ø
Machine Size L x W x H (H1)	30" x 40" x 49" (55") (762 x 1016 x 1232 mm) (1397 mm)	55" x 40" x 51" (1397 x 1026 x 1295 mm)	66" x 48" x 51" (1675 x 1206 x 1300 mm)
Machine Weight	442 lb (200 kg)	880 lb (400 kg)	1200 lb (544 kg)

* All specifications are subject to change without notice.

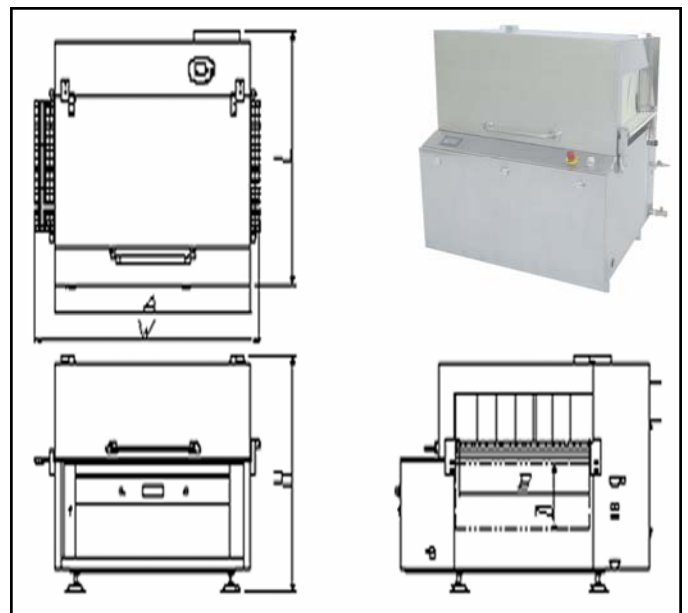
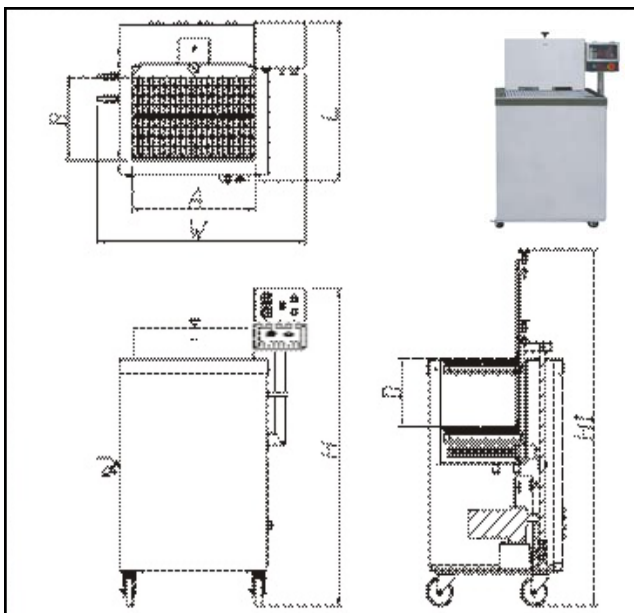

Vacu-Fresh® by MPBS Industries

Distributed by:

400