

Vacu-Fresh®

Ready

Fresh

GO!

VACUUM PACKAGING MACHINES

Nozzle Series



Enhances Shelf Life
Enhances Color & Taste
Reduces Shrink
Reduces Oxidation

VFN-600, VFN-1000, VFN-1500, VFN-2000, VFN-2500, VFN-3000

FEATURES: Heavy-duty stainless steel construction • Busch® pump¹ • Casters • Gas flush
Foldable table • IP56 Computerized water resistant control panel (12-Programs with oil indicator)

Options: Bag holding clips • Top and bottom seal • Custom voltage • Sensor control • Soft air
Gas tank • Digital seal temperature control system • Custom sizes

[¹] Except on VFN-600

We provide
technical support and
service for all machines
that we sell

MPBS INDUSTRIES

Equipment for Industrial Food Processing & Packaging

2820 East Washington Blvd. Los Angeles CA 90023
323-268-8514 ♦ 323-268-6305 (fax) ♦ www.mpbs.com
Hours: 8:00 - 4:30 PM
Se Habla Espanol



Since 1938

VFN Nozzle Series Vacuum Packaging Machines

Technical Specifications

Models	VFN-600	VFN-1000	VFN-1500	VFN-2000	VFN-2500	VFN-3000
Seal Bar Length	23.6" (600 mm)	39.3" (1000 mm)	59.0" (1500 mm)	78.7" (2000 mm)	98.4" (2500 mm)	118" (3000 mm)
Vacuum Pump Capacity	6 m ³ /h (½ HP)	21 m ³ /h (1¼ HP)	21 m ³ /h (1¼ HP)	40 m ³ /h (2 HP)	40 m ³ /h (2 HP)	63 m ³ /h (3 HP)
Power/amps	.37 kW / 2.3 amps	.75 kW / 6.5 amps	.75 kW / 6.5 amps	1.1 kW / 7.5 amps	1.1 kW / 7.5 amps	1.5 kW / 9 amps
Voltage	100 V / 60 Hz / 1Ø	110 V / 60 Hz / 1 Ø	110 V / 60 Hz / 1 Ø	230 V / 60 Hz / 3 Ø	230 V / 60 Hz / 3 Ø	230 V / 60 Hz / 3 Ø
Machine Size L x W x H	28.5" x 47.5" x 59" (720 x 1210 x 1500 mm)	28.5" x 47.5" x 59" (720 x 1210 x 1500 mm)	28.5" x 67.3" x 59" (720 x 1710 x 1500 mm)	35.8" x 87" x 59" (910 x 2210 x 1500 mm)	35.8" x 106.6" x 59" (910 x 2710 x 1500 mm)	35.8" x 126.3" x 59" (910 x 3210 x 1500 mm)
Machine Weight	385 lb / 175 kg	396 lb / 180 kg	484 lb / 220 kg	616 lb / 280 kg	704 lb / 320 kg	880 lb / 400 kg

All specifications are subject to change without notice

► Technical Data

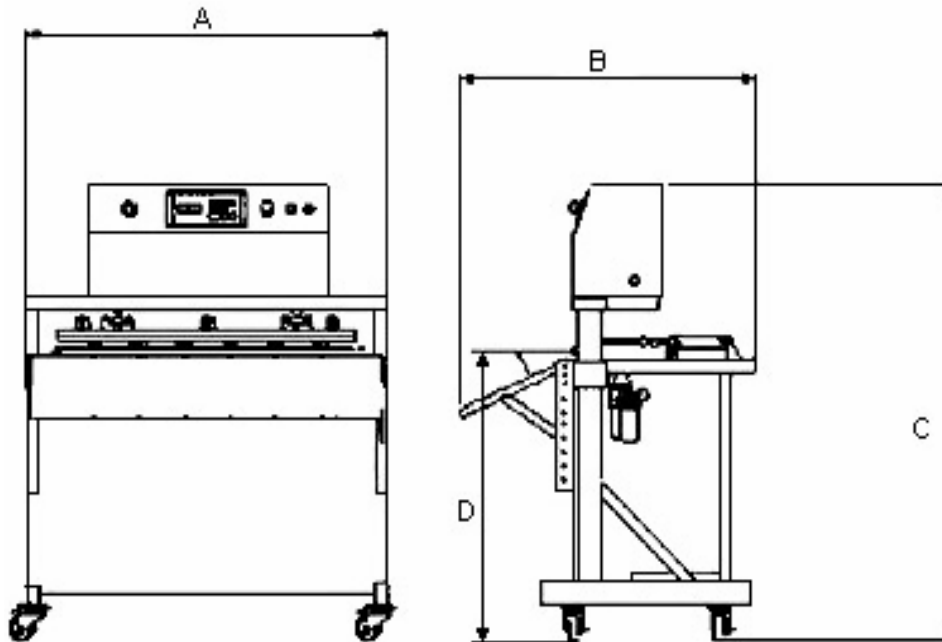

Nozzle Series® by MPBS Industries